

Tecnologia em **Moldes para Picolés**

Tecnología en Moldes para Paletas
Technology in Ice Lolly Molds



Índice

Índice | Index

ATA 14

Modelos com 14 cavidades

Modelos con 14 cavidades | Models with 14 cavities

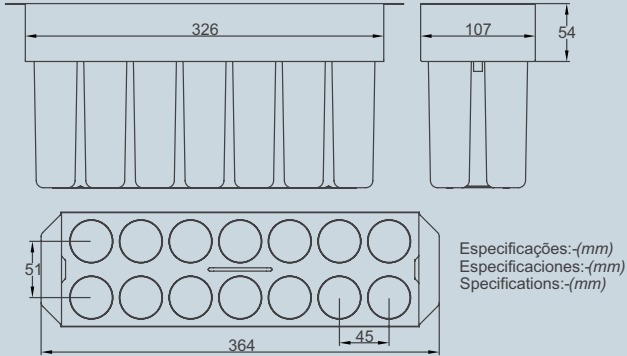

ATA 22

Modelos com 22 cavidades

Modelos con 22 cavidades | Models with 22 cavities

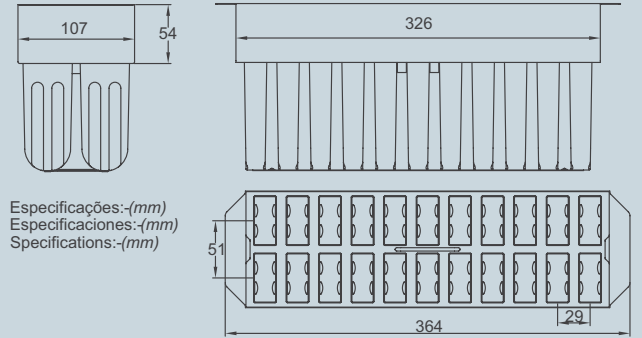

ATA 18

Modelos com 18 cavidades

Modelos con 18 cavidades | Models with 18 cavities

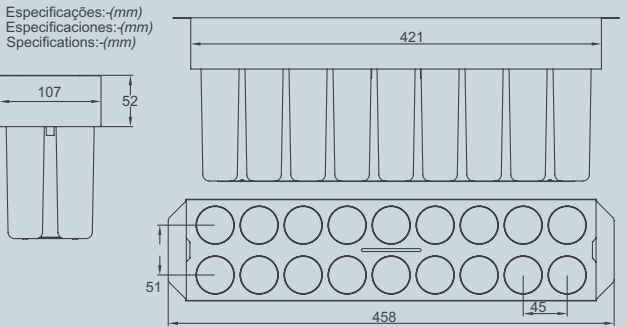

ATA 28

Modelos com 28 cavidades

Modelos con 28 cavidades | Models with 28 cavities

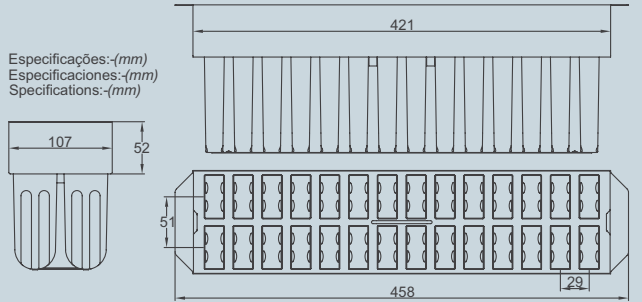

ATA 26

Modelos com 26 cavidades

Modelos con 26 cavidades | Models with 26 cavities

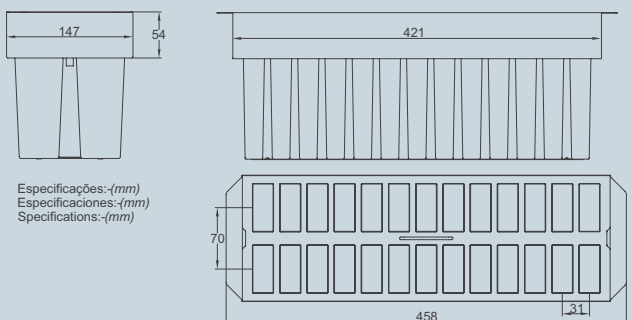

ATA 12

Modelos com 12 cavidades

Modelos con 12 cavidades | Models with 12 cavities

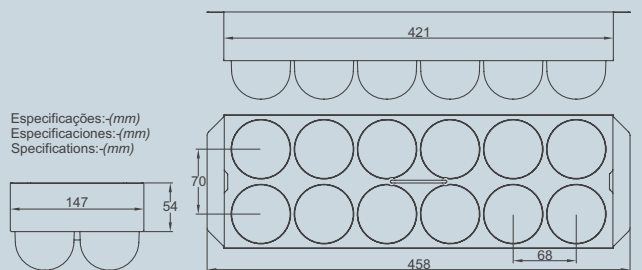

ATA 14 / ATA 18



Modelos com 14 e 18 cavidades

Modelos con 14 y 18 cavidades
Models with 14 and 18 cavities



PRODUTOS PATENTEADOS | PATENTED PRODUCTS
PRODUCTOS PATENTADOS | PATENTED PRODUCTS

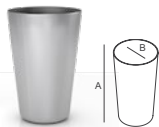

Lollitinha

A: 52 mm
B: 35 mm
ml/cc: 38



Lollita

A: 63 mm
B: 35 mm
ml/cc: 45

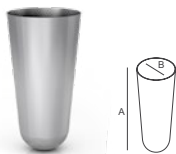

Lollita Arredondada

A: 68 mm
B: 35 mm
ml/cc: 48



Lolly Arredondada

A: 94,5 mm
B: 38 mm
ml/cc: 75

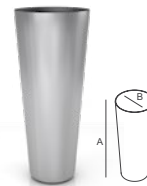

Lolly

A: 90 mm
B: 38 mm
ml/cc: 75

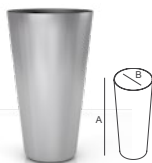

Lolly 60 ml

A: 74,7 mm
B: 38 mm
ml/cc: 60



Ituzinho

A: 115 mm
B: 38 mm
ml/cc: 117

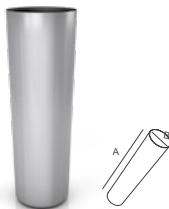

Mini-itu 60 ml

A: 99,5 mm
B: 30 mm
ml/cc: 60



Drill

A: 115 mm
B: 38 mm
ml/cc: 95



Tetra

A: 115 mm
B: 38 mm
ml/cc: 96



Minidrill

A: 100,5 mm
B: 31 mm
ml/cc: 48



Coração

A: 100 mm
B: 30 mm
C: 26,5 mm
ml/cc: 48

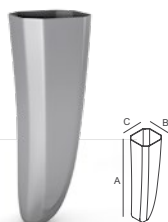

Banana 55 ml

A: 101,5 mm
B: 28 mm
C: 30 mm
ml/cc: 55

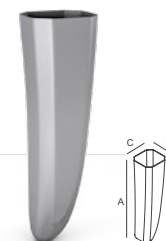

Banana 60 ml

A: 109 mm
B: 28 mm
C: 30 mm
ml/cc: 60



Banana 66 ml

A: 117 mm
B: 28 mm
C: 30 mm
ml/cc: 66

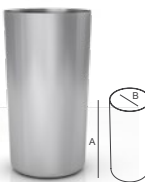

Recife

A: 84,5 mm
B: 38 mm
ml/cc: 85

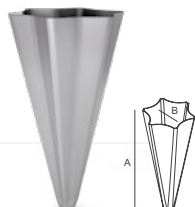

Frevo

A: 98,5 mm
B: 43 mm
ml/cc: 43
APENAS 18 CAVIDADES
ONLY 18 CAVITIES
SÓLO 18 CAVIDADES



Coelho

A: 113 mm
B: 25,5 mm
C: 45,8 mm
ml/cc: 75
APENAS 18 CAVIDADES
ONLY 18 CAVITIES
SÓLO 18 CAVIDADES

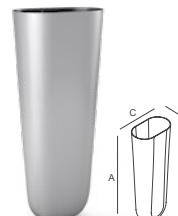

Soft

A: 107,5 mm
B: 25 mm
C: 43 mm
ml/cc: 70
APENAS 18 CAVIDADES
ONLY 18 CAVITIES
SÓLO 18 CAVIDADES

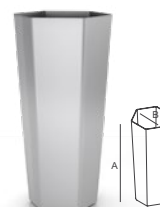

Hexagonal

A: 98,5 mm
B: 35 mm
ml/cc: 82

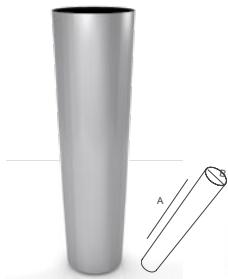

Catarina Lisa 80 ml

A: 129,5 mm
B: 31,58 mm
ml/cc: 80



Catarina Lisa 140 ml

A: 200 mm
B: 35 mm
ml/cc: 140

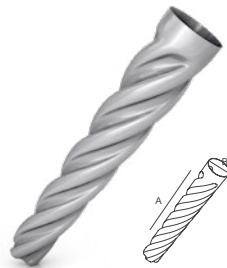

Catarina Helicoidal

A: 200 mm
B: 35 mm
ml/cc: 118



Bombom 11 ml

A: 22,5 mm
B: 29 mm
ml/cc: 11



Bombom 17 ml

A: 25 mm
B: 34,5 mm
ml/cc: 17



Bombom 23 ml

A: 26,5 mm
B: 38 mm
ml/cc: 23



Bombom no Palito

A: 35 mm
B: 30 mm
ml/cc: 22

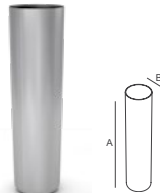

**Recheio Drill ou
Mescla de Sabores**

A: 90,5 mm
B: 24,7 mm
ml/cc: 41

ATA 22 / ATA 28

Modelos com 22 e 28 cavidades

Modelos con 22 y 28 cavidades
Models with 22 and 28 cavities



PRODUTOS PATENTEADOS | PATENTED PRODUCTS

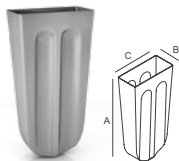

Baianinho

A: 83 mm
B: 19 mm
C: 43 mm
ml/cc: 45

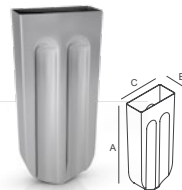

Brida 63 ml

A: 96 mm
B: 19 mm
C: 43 mm
ml/cc: 63

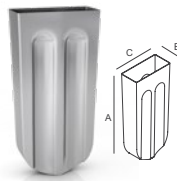

Brida 58 ml

A: 90 mm
B: 19 mm
C: 43 mm
ml/cc: 58

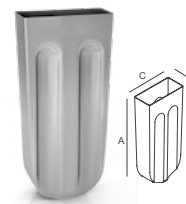

Brida Frut 68 ml

A: 96 mm
B: 21 mm
C: 43 mm
ml/cc: 68

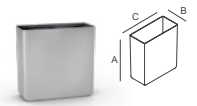

Bombom Quadrado

A: 44 mm
B: 19 mm
C: 43,5 mm
ml/cc: 35

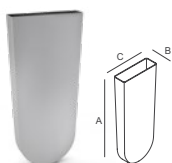

Recheio 22 ml

A: 79,5 mm
B: 11 mm
C: 34 mm
ml/cc: 22

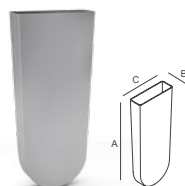

**Recheio 30 ml ou
Mini-Picolé**

A: 91 mm
B: 17 mm
C: 34,5 mm
ml/cc: 30

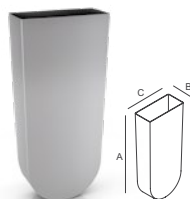

Brilis

A: 96 mm
B: 19 mm
C: 43 mm
ml/cc: 66

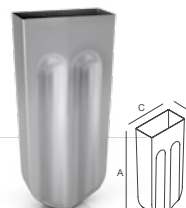

Megamid 80 ml

A: 101,5 mm
B: 22 mm
C: 45 mm
ml/cc: 80

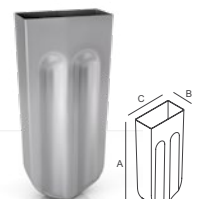

Megamid 72 ml

A: 95 mm
B: 22 mm
C: 45 mm
ml/cc: 72

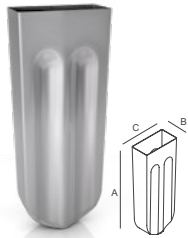

Megamex

A: 114,5 mm
B: 22 mm
C: 45 mm
ml/cc: 90



Wave 63 ml

A: 97 mm
B: 21,5 mm
C: 43 mm
ml/cc: 63

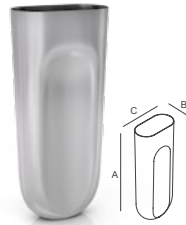

Wave 70 ml

A: 106 mm
B: 21,5 mm
C: 43 mm
ml/cc: 70

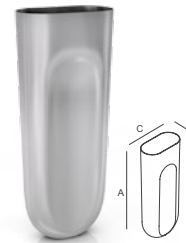

Wave 78 ml

A: 118,5 mm
B: 21,5 mm
C: 43 mm
ml/cc: 78

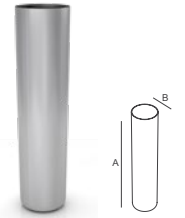

Tutti Colore 45 ml

A: 101 mm
B: 24,7 mm
ml/cc: 45

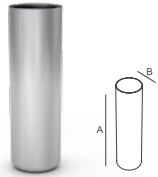

Tutti Colore 35 ml

A: 82 mm
B: 24,7 mm
ml/cc: 35

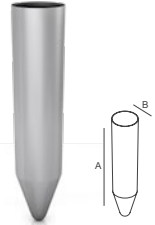

Lápis

A: 113,5 mm
B: 24,7 mm
ml/cc: 44

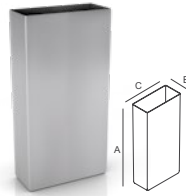

Skimo

A: 90 mm | B: 19 mm
C: 43 mm | ml/cc: 70

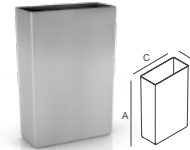

Skiminho

A: 64 mm
B: 19 mm
C: 43 mm
ml/cc: 50

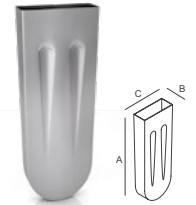

Brida Slim

A: 109,5 mm
B: 15 mm
C: 40 mm
ml/cc: 55

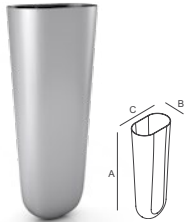

Soft

A: 107,5 mm
B: 25 mm
C: 43 mm
ml/cc: 70

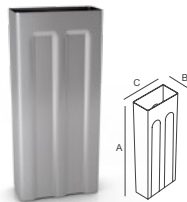

Freezy

A: 93 mm
B: 19 mm
C: 43 mm
ml/cc: 68

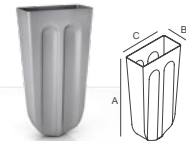

Mini Brida 35 ml

A: 72 mm | B: 17 mm
C: 42 mm | ml/cc: 35

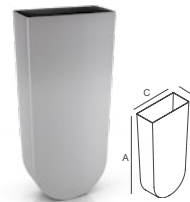

Megamaxxi

A: 95,2 mm
B: 23 mm
C: 45,2 mm
ml/cc: 80

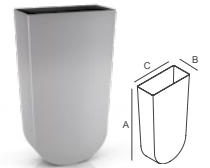

Mini Extrusado

A: 71,5 mm
B: 18,6 mm
C: 41,8 mm
ml/cc: 48

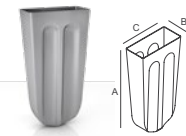

Mini Brida 30 ml

A: 64,5 mm | B: 17 mm
C: 42 mm | ml/cc: 30

APENAS 28 CAVIDADES
ONLY 18 CAVITIES
SÓLO 18 CAVIDADES

LATA 26 / LATA 12

Modelos com 26 e 12 cavidades

Modelos con 26 y 12 cavidades
Models with 26 and 12 cavities



PRODUTOS PATENTEADOS | PATENTED PRODUCTS



Maxibrida

A: 106 mm
B: 23 mm
C: 54 mm
ml/cc: 100

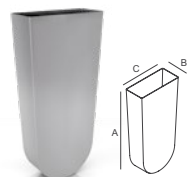

Maximid 108 ml

A: 106 mm
B: 23 mm
C: 54 mm
ml/cc: 108

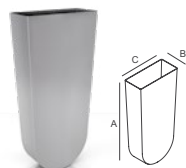

Maximid 100 ml

A: 99,5 mm
B: 23 mm
C: 54 mm
ml/cc: 100

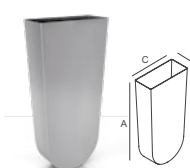

Maximid 95 ml

A: 95,5 mm
B: 23 mm
C: 54 mm
ml/cc: 95

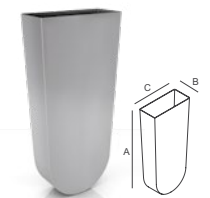

Maxim's

A: 114,5 mm
B: 23 mm
C: 54 mm
ml/cc: 117

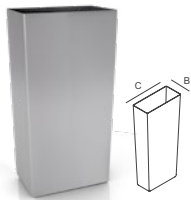

Mich

A: 114,5 mm
B: 23 mm
C: 54 mm
ml/cc: 123

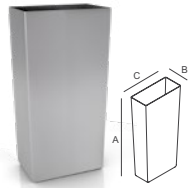

Michmid

A: 106 mm
B: 23 mm
C: 54 mm
ml/cc: 113

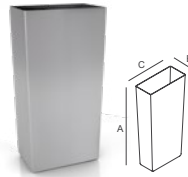

Michmid 100 ml

A: 94 mm
B: 23 mm
C: 54 mm
ml/cc: 100

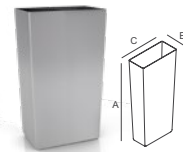

Mini Paleta

A: 86 mm
B: 22,5 mm
C: 53 mm
ml/cc: 89

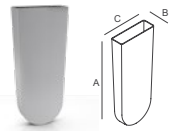

Recheio 28 ml

A: 70 mm
B: 14 mm
C: 33,5 mm
ml/cc: 28

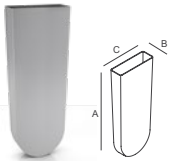

Recheio 35 ml

A: 90 mm
B: 15 mm
C: 34 mm
ml/cc: 35

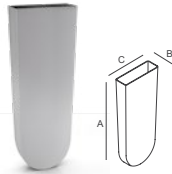

Recheio 39 ml

A: 97 mm
B: 15 mm
C: 34,6 mm
ml/cc: 39

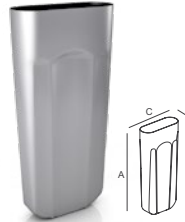

Carioca

A: 115 mm
B: 21 mm
C: 55 mm
ml/cc: 85

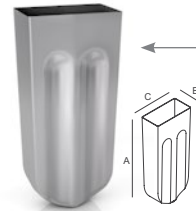

Megamid 87 ml

A: 101,5 mm
B: 24,5 mm
C: 43,5 mm
ml/cc: 87

Molde com 26 cavidades, mas com as medidas do molde de 28

Molde de 26 cavidades, pero con las medidas del molde de 28

A 26-Cavity Mold, but with the 28-cavity mold measures

Modelos desenvolvidos apenas para 12 cavidades

Modelos desarrollados para sólo 12 cavidades

Models developed for 12 cavities only

Modelo desenvolvido apenas para 36 cavidades

Modelo desarrollado para sólo 36 cavidades

Model developed for 36 cavities only



Monoporção

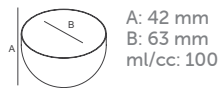

A: 42 mm
B: 63 mm
ml/cc: 100



Monoporção 150 ml

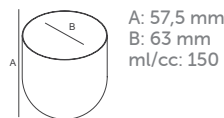

A: 57,5 mm
B: 63 mm
ml/cc: 150



Morezinha

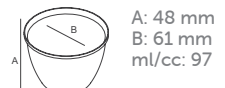

A: 48 mm
B: 61 mm
ml/cc: 97



Quadrinho



A: 16,5 mm
B: 24 mm
C: 24 mm
ml/cc: 11

Modelos desenvolvidos apenas para 18 e 38 cavidades

Modelos desarrollados para sólo 18 y 38 cavidades

Models developed for 18 and 38 cavities only



Bombom Coração



A: 17 mm
B: 31 mm
C: 27 mm
ml/cc: 11



Bombom 11 ml



A: 26 mm
B: 25,5 mm
ml/cc: 11

DIFERENCIAIS ATAFORMA

Diferenciales Ataforma | Ataforma differentials

- Aço inox 304 L em chapa 0,5mm certificado, **proporcionando alta produção**;
- Acero Inoxidable 304 L en plancha 0,5mm certificado, proporcionando alta producción;
- Certified 304L Stainless Steel with a 0.5mm Sheet providing high production;
- **Acabamento liso e uniforme** que impede o acúmulo de resíduos;
- Acabamiento liso y uniforme que impide el acúmulo de residuos;
- Smooth uniform finish preventing from residue accumulation;
- Única com **polimento de superfície**, produto de fácil limpeza e higienização;
- Única con pulido de superficie; producto de fácil limpieza e higienización;
- Unique surface polishing; easy-to-clean product;
- **Travamento das cavidades altamente resistente (Patente)**;
- Trabamiento de las cavidades altamente resistente (Patente);
- Highly resistant cavity locking (Patent);
- **Molde extremamente leve** e de fácil extração;
- Molde extremamente ligero y de fácil extracción;
- Extremely light; easily extractable mold;
- **Rapidez no congelamento**.
- Rapidez en el congelamiento.
- Fast Freezing.

Uma nova realidade para os empreendedores, com sabor de tecnologia de ponta!

Una nueva realidad para los emprendedores, ¡con sabor a tecnología de punta!

A new reality for entrepreneurs, with a state-of-the-art technology flavor!

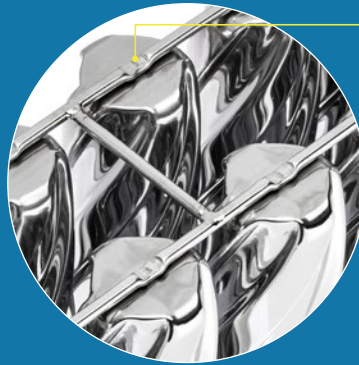

NOVO TRAVAMENTO DAS CAVIDADES

COM BARRA DE AÇO INOX 304L EM SOLDA POR RESISTÊNCIA SOMENTE NA ÁREA DE CONTATO, O QUE FACILITA A LIMPEZA DO PRODUTO.

Nuevo trabamiento de las cavidades: con barra de acero inoxidable 304l en soldadura por resistencia solamente en el área de contato, facilitando la limpieza del producto.

New cavity locking: with a 304l stainless steel bar in resistance welding only in the contact area, making the cleaning of the product much easier.

Com friso longitudinal e um aumento na espessura da borda, juntas as formas criam um espaço vazio que diminui a área de contato entre elas e a possibilidade de respingo, para o lado interno, durante a fabricação dos picolés.

Con friso longitudinal y un aumento en el espesor del borde, juntos, crean los moldes un espacio vacío que disminuye el área de contacto entre ellos y la posibilidad de salpicadura, hacia el lado interno, durante la fabricación de paletas heladas.

With a longitudinal frieze and increased edge thickness, all together, the molds create an empty space diminishing the area of contact between them, as well as the possibility of splash towards the inside during ice pop manufacturing.

AGORA, COM MAIOR RESISTÊNCIA A IMPACTO! E O MELHOR: MANTENDO A LEVEZA DE SEMPRE, O QUE AUMENTA SUA PRODUTIVIDADE E FACILITA O MANUSEIO DURANTE O PROCESSO DE PRODUÇÃO.

!Ahora con mayor resistencia a impacto! y lo mejor: manteniendo la ligereza de siempre, aumentando su productividad y facilitando el manejo durante el proceso de producción.

Now with higher impact resistance! and the best: keeping its usual lightness, increasing productivity and making its handling during the process much easier.

PRODUTO PATENTEADO

- ☑ TRAVAMENTO
- ☑ SISTEMA DO CORPO

PRODUCTO PATENTADO

- TRABAMIENTO
- SISTEMA DEL CUERPO

A PATENTED PRODUCT

- LOCKING
- BODY SYSTEM

POLIMENTO DE SUPERFÍCIE

GARANTE MELHOR LIMPEZA E HIGIENIZAÇÃO

PULIDO DE SUPERFÍCIE:
GARANTIZA MEJOR LIMPIEZA E HIGIENIZACIÓN

SURFACE POLISHING
BETTER CLEANING AND GUARANTEED HYGIENE



GELO SABORIZADO DA FRUTA

Hielo Saborizado de Fruta
Flavored Fruit Ice
Ghiaccio Aromatizzato di Fruta

Conheça nossa linha de formas
para produzir lindos gelos para drinks
e, também, sorvetes

Conozca nuestros moldes para producir preciosos hielos para bebidas y también helados
Get to know our molds for you to prepare beautiful fruit ice for drinks and ice-cream
Conoscere i nostri stampi per produrre un bellissimo ghiaccio per bevande ed anche per gelati



Gelo Cubo 200 ml

Hielo Cubo 200 ml
Cube Ice 200 ml
Chiaccio Cubo 200 ml

A: 120 mm
B: 42,5 mm
C: 42,5 mm
ml/cc: 200



Gelo Cubo Fatiado de 35 ml

Hielo Rebanado 35 ml
Sliced Cube 35 ml
Ghiaccio Affettato 35 ml

A: 44 mm
B: 19 mm
C: 43,5 mm
ml/cc: 35

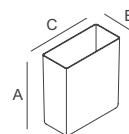

Gelo Quadrado de 14,5 ml / 11ml

Hielo Cuadrado 14,5 ml / 11 ml
Square Ice 14.5 ml / 11 ml
Ghiaccio Quadrato 14,5 ml / 11 ml

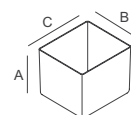

A: 23 mm
B: 24 mm
C: 24 mm
ml/cc: 14,5



Gelo Bombom de 23 ml

Hielo Bombón 23 ml
Bombon Ice 23 ml
Ghiaccio Bonbon 23 ml

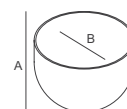

A: 26,5 mm
B: 38 mm
ml/cc: 23

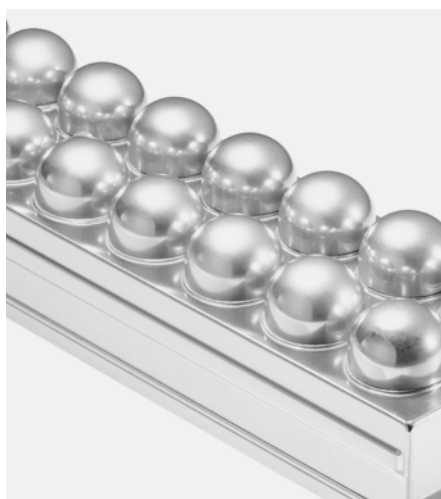

Gelo Cubo 70 ml

Hielo Cubo 70 ml
Cube Ice 70 ml
Ghiaccio Cubo 70 ml

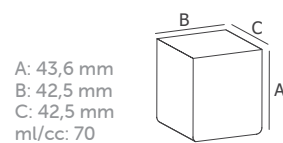

Meia bola para gelo 100ml

Gelo Meia Bola 100 ml
Half Scoop Ice 100 ml
Mezza Pallina di Ghiaccio 100 ml

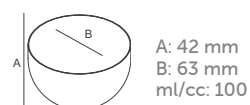

Gelo Coração para gelo de 14 ml / 11ml

Hielo Corazón 14 ml / 11 ml
Heart-Shaped Ice 14 ml / 11 ml
Ghiaccio Cuore 14 ml / 11 ml

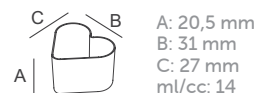

Extrator de Pino

Extractor de Pines
Pin Puller
Estrattore di perni

Sistema criado pela Ataforma que revolucionou o mercado de sorvetes no Brasil e no mundo e, hoje, é utilizado na produção dos gelos.

Sistema creado por Ataforma que revolucionó el mercado de helados en Brasil y en todo el mundo, y hoy se utiliza en la producción de hielos.

A system created by Ataforma which revolutionized the Ice-Cream Market in Brazil and all over the world, and is also used in Fruit Ice Production.

Sistema creato dall' Ataforma che ha rivoluzionato il mercato di gelati in Brasile e nel mondo, e oggi si usa nella produzione di ghiaccio aromatizzato.

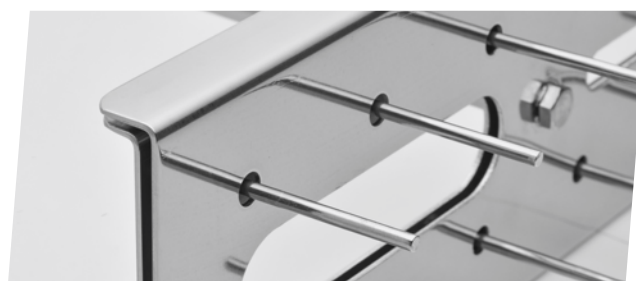
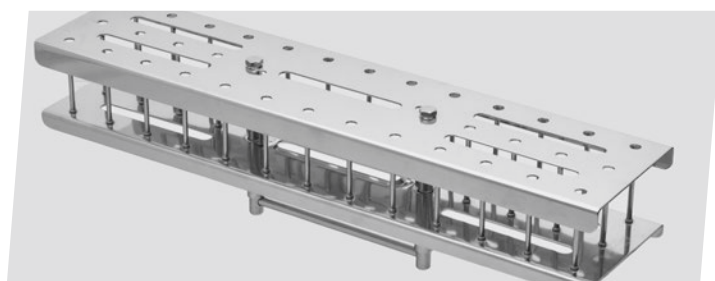
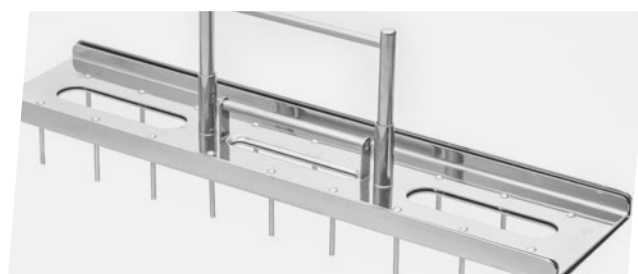

Gelo Bombom de 11 ml

Hielo Bombón 11 ml
Bombon Ice 11 ml
Ghiaccio Bonbon 11 ml

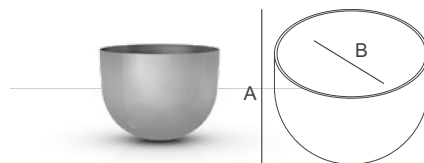

A: 25,5 mm
B: 26 mm
ml/cc: 11



Gelo Cubo 110 ml

Hielo Cubo 110 ml
Cube Ice 110 ml
Chiaccio Cubo 110 ml

A: 34,6 mm
B: 50,6 mm
C: 63,5 mm
D: 33 mm
E: 49 mm
ml/cc: 110

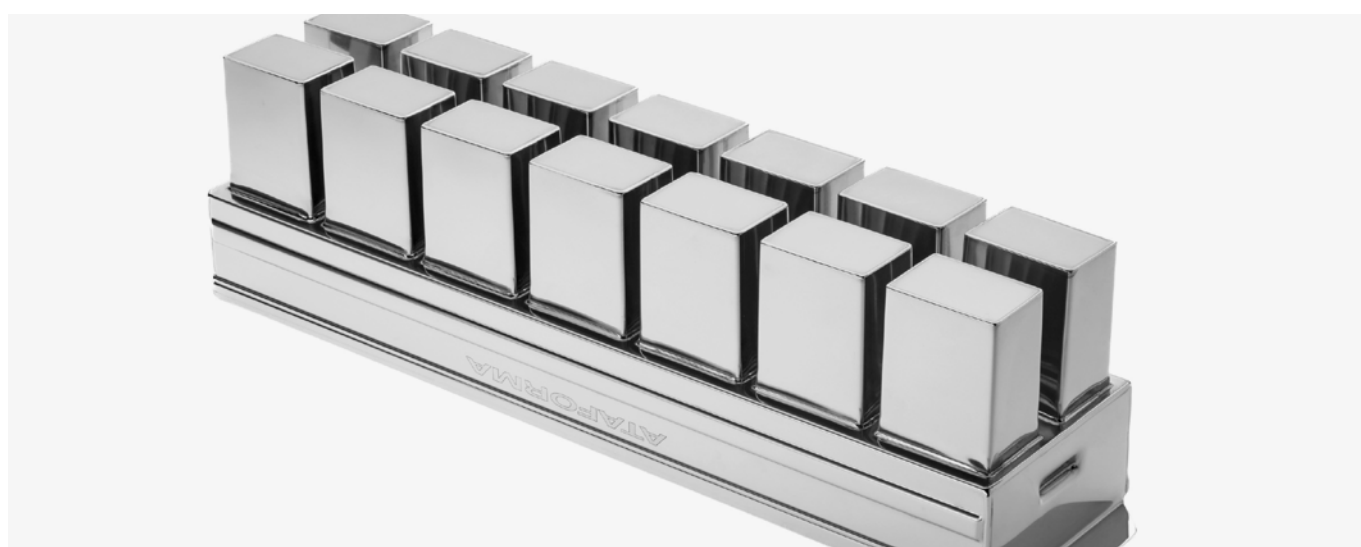
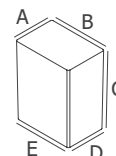

Gelo Cubo 220 ml

Hielo Cubo 220 ml
Cube Ice 220 ml
Chiaccio Cubo 220 ml

A: 36 mm
B: 52 mm
C: 121 mm
D: 33 mm
E: 49 mm
ml/cc: 220

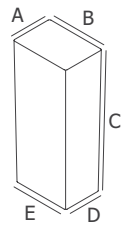

PRODUTO PATENTEADO

PICOCHURROS

Modelo recheado, por inteiro,
da primeira à última mordida

PRODUCTO PATENTADO
PICOCHURROS

Modelo totalmente relleno,
desde el primer bocado hasta el último

PATENTED MODEL
PICOCHURROS

Model stuffed in full,
from the first to the last bite

MODELLO BREVETTATO
PICOCHURROS

Modello farcito in pieno,
dal primo all'ultimo morso





Assista ao nosso
vídeo institucional

Asista a nuestro video institucional
Watch our institutional video
Guarda il nostro video istituzionale

Lançamentos

Lanzamientos
Releases

Molde de Bombom Coração: este modelo produz 38 bombons de sorvete, de uma única vez, em formato de coração. Para extrair os bombons utiliza-se o tradicional extrator de pinos desenvolvido com a tecnologia Ataforma.

Molde de Bombón Corazón: produce este modelo 38 bombones de helado de una sola vez, en formato de corazón. Se utiliza para sacar los bombones el tradicional extractor con pinos desarrollado con la Tecnología Ataforma.

Heart Bombon Mold: this model produces 38 heart-shaped ice cream bombons at once. The traditional pinned extractor is used for releasing the bombons. It was developed by Ataforma Technology.

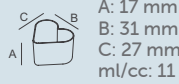

Molde de Bombom Quadrado: este modelo produz 36 bombons de sorvete, de uma única vez, em formato de coração. Para extrair os bombons utiliza-se o tradicional extrator de pinos desenvolvido com a tecnologia Ataforma.

Molde de Bombón Cuadrado: produce este modelo 36 bombones de helado de una sola vez, en formato de corazón. Se utiliza para sacar los bombones el tradicional extractor con pinos desarrollado con la Tecnología Ataforma.

Square Bonbon Mold: this model produces 36 heart-shaped ice cream bombons at once. The traditional pinned extractor is used for releasing the bombons. It was developed by Ataforma Technology.

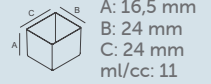

PICOLÉ "EXTRUSADO"

Megamaxxi: o único molde com 28 cavidades para fazer picolé "extrusado". O tradicional sorvete de massa no palito com 80 ml é ideal para a sua linha Premium. As cavidades do Megamaxxi possuem espessuras maiores, e só foi possível fabricá-lo devido à Tecnologia Ataforma, visto que o espaço entre as cavidades é mínimo, porém, suficiente para o banho de chocolate. A vantagem do Megamaxxi é que os extratores (paliteiras) e os alinhadores são os mesmos daqueles moldes Ataforma com 28 cavidades que você já utiliza em sua linha de produção. Estamos seguros de que o seu cliente irá gostar desta novidade!

Megamaxxi: el único molde con 28 cavidades para hacer paletas "extrusadas". El tradicional helado de masa en el palillo con 80 ml es ideal para su línea Premium. Las cavidades del Megamaxxi poseen espesores más grandes, y sólo fue posible fabricarlo debido a la Tecnología Ataforma, puesto que el espacio entre las cavidades es mínimo, sin embargo, suficiente para el baño de chocolate. La ventaja del Megamaxxi es que los extractores (palilleras) y los alineadores son los mismos de aquellos moldes Ataforma con 28 cavidades, los cuales ya se utilizan en su línea de producción. ¡Estamos seguros de que a su cliente le va a encantar esta novedad!

Megamaxxi: the only 28-cavity mold for "extruded" stick ice cream. The traditional 80 ml stick ice cream is ideal for your Premium line. The Megamaxxi cavities have larger thickness, and it was only possible to manufacture it due to Ataforma Technology, since the space between the cavities is the least, however, it is enough for chocolate topping. Megamaxxi's advantage is that the extractors (stick holders) as well as the aligners are the same as those 28-cavity Ataforma molds you already make use of in your production line. We are sure that your customer is going to enjoy this novelty!

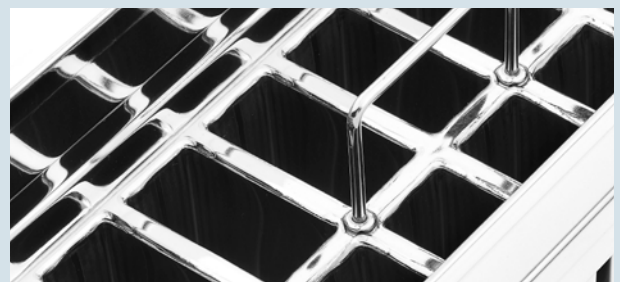
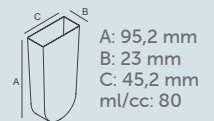

Extractor Universal

Extractor Universal
Universal Extractor

Quem cria, recria.

De funcionalidade reconhecida em todo mundo, o revolucionário extrator com padrão diferenciado de regulagem na alavanca foi um produto desenvolvido pela Ataforma há 25 anos ®. Ele foi projetado para prender e liberar palitos.

Como o setor sorveteiro inova com relativa frequência, a Ataforma igualmente investe na praticidade. Após criteriosos estudos, importantes modificações foram efetuadas no extrator, gerando o que denominamos extrator "universal", que é adequado para palitos planos [6, 9, 10, 13, 14 mm], incluindo o tradicional palito hélice. Deste modo, a nova ferramenta unifica em um só produto as funções de um ou outro extrator para diferentes padrões de palito.

Quien lo crea, lo recrea.

De funcionalidad reconocida en todo el mundo, el revolucionario extractor con estándar diferenciado de regulaje en la palanca fue un producto desarrollado por Ataforma hace 25 años ®. Diseñado para prender y liberar palillos.

Puesto que se innova el sector heladero con relativa frecuencia, invierte Ataforma igualmente en la practicidad. Tras criteriosos estudios, se efectuaron importantes modificaciones en el extractor, engendrando lo que denominamos el extractor "universal", que es adecuado para palillos llanos (6, 9, 10, 13 y 14 mm), incluso el tradicional palillo hélice. Así, unifica la nueva herramienta en un sólo producto las funciones de uno o outro extractor para distintas clases de palillo.

Ataforma es lo que hay de mejor en moldes y accesorios para la fabricación de paletas heladas. ¡Esperen las próximas novedades!

Who creates, re-creates.

With a functionality recognized all over the world, the revolutionary extractor with a differentiated standard of lever adjustment was a product developed by Ataforma 25 years ago ®. It was designed to fasten and release popsicle sticks.

As the ice cream sector innovates relatively often, Ataforma also invests in practicality. After criterious studies, important modifications were carried out in the extractor, bringing about what we denominate a "universal" extractor, which is suitable to flat sticks (6, 9, 10, 13, 14 mm), including the traditional propeller stick. In this way, the new tool unifies into one product the functions of either extractors for different stick standards.

Ataforma is the best choice when it comes to molds and accessories for popsicle manufacturing. Novelties coming soon!

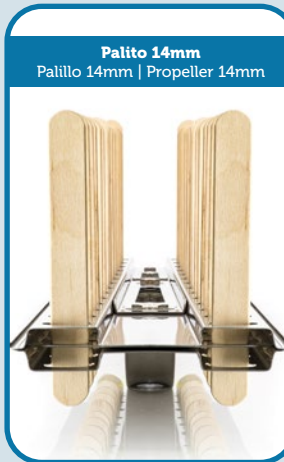
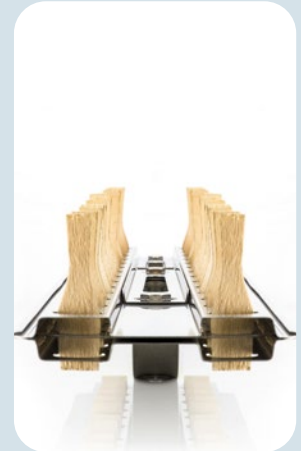
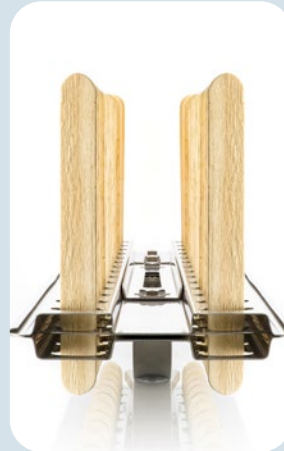

Palito 14mm
Palillo 14mm | Propeller 14mm

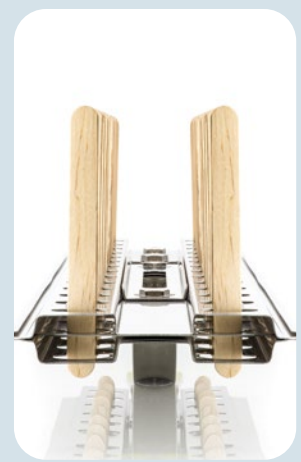

Palito 6mm
Palillo 6mm | Propeller 6mm

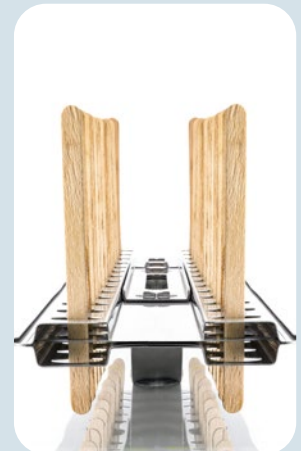

Palito Hélice
Palillo Hélice | Propeller Stick

EXTRATORES PARA PALITOS

- 14 e 18 Furos
- 22 e 28 Furos
- 26 Furos

Extratores Especiais

- 14 e 18 Furos (Minidrill, Catarina Helicoidal e Drill)
- 12 furos (Moreninha)

Produzidos em aço inoxidável 304, essa ferramenta agiliza o desmolde, extraindo todos os produtos ao mesmo tempo. Podem ser desmontados para limpeza, mas ao montar observe a seguinte orientação:

Friso para travamento - aperto moderado para não danificar os frisos.

EXTRACTORES PARA PALILLOS

- 14 y 18 Agujeros
- 22 e 28 Agujeros
- 26 Agujeros

Extractores Especiales

- 14 e 18 Agujeros (Minidrill, Catarina Helicoidal e Drill)
- 12 Agujeros (Moreninha)

Producidos en acero inoxidable 304, agilizan el desmolde, extrayendo todos los productos al mismo tiempo. Pueden ser desmontados para limpieza, pero al montar observe la siguiente orientación:

Resalto para bloqueo - presión moderado para no estropear los resaltos.

STICK EXTRACTORS

- 14 and 18 Holes
- 22 e 28 Holes
- 26 Holes

Special Extractors

- 14 e 18 Holes (Minidrill, Catarina Helicoidal e Drill)
- 12 Holes (Moreninha)

Built in stainless steel 304, this tool speeds up the extraction from the mold, extracting all the products at the same time from the mold.

It can be disassembled for cleaning, but when re-assembling it, please observe the following:

Edge for locking - use moderate pressure in order to avoid damaging the edges.

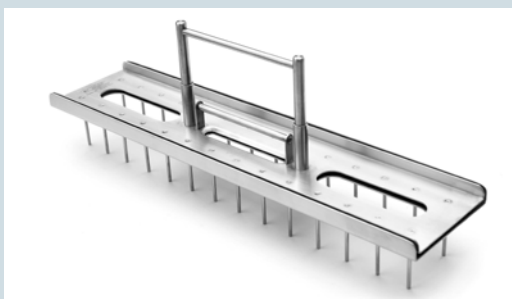

EXTRATORES DE PINOS

12, 14 e 18 pinos (para monoporção e bombons) 22 e 28 pinos (para picolé sem palito)

EXTRACTORES CON ALFILERES

12, 14 y 18 alfileres (para monoporción, bonbons) 22 y 28 alfileres (eskimo sin palillo)

STICKLESS HOLDERS

12, 14 and 18 pins (for monoportion, bonbons) 22 and 28 pins (eskimo without stick)

EXTRATOR PARA MORENINHA + SUPORTE: 12 furos
EXTRACTOR PARA MORENINHA + SOPORTE: 12 agujeros
CONE HOLDER FOR MORENINHA + BASE: 12 holes

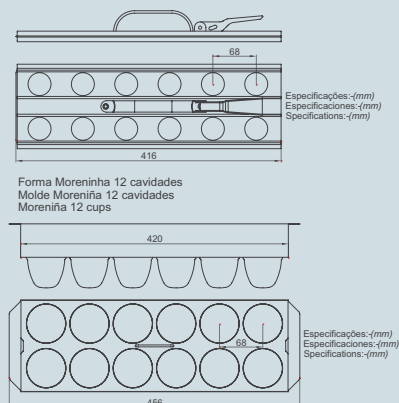

ALINHADORES DE PALITOS

Fabricados em alumínio, centraliza e ordena os palitos na altura exata para posteriormente serem fixados pelo extrator de palitos.

Eles são duplos, ou seja, com um alinhador você prepara os palitos para dois extratores. Portanto, nossos alinhadores possuem:

- 28 tubos
- 36 tubos
- 36 tubos especial para produção de picolé nos moldes Catarina Lisa e Catarina Helicoidal
- 44 tubos
- 52 tubos
- 52 tubos especial para palito hélice
- 56 tubos



ALINEADORES DE PALILLOS

Fabricados en aluminio, centralizan y ponen en orden los palillos en la altura exacta para posterior fijación por el extractor de palillos. Ellos son dobles, o sea, con un alineador se preparan los palillos para dos extractores. Por eso, nuestros alineadores poseen:

- 28 tubos
- 36 tubos
- 36 tubos especial para producción de paletas en los moldes Catarina Lisa y Catarina Helicoidal
- 44 tubos
- 52 tubos
- 52 tubos especial para palillo hélice
- 56 tubos

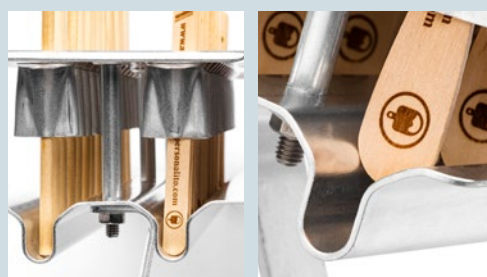

STICK ALIGNERS

Built in aluminum, it aligns and places the sticks in order at the exact height for being fixed by the stick holder. They are double, that is, with one aligner you prepare the sticks for two holders. Thus, our aligners have:

- 28 tubes
- 36 tubes
- 36 tubes, special for use with the molds Catarina Lisa and Catarina Helicoid
- 44 tubes
- 52 tubes
- 52 tubes special for helix sticks
- 56 tubes

Fundada em 1984, a Ataforma se tornou referência no mercado. Seu produto é exportado para mais de 50 países, sendo líder do segmento no Brasil. A empresa está localizada em área urbana de 30.000 m², que contempla complexo fabril, grêmio recreativo e área verde com função ecológica e lazer.

Fundada en el 1984, Ataforma se ha convertido en referencia en el mercado. Se exporta su producto a más de 50 países, siendo líder del segmento en Brasil. Se ubica la empresa en área urbana de 30.000 m², abarcando complejo fabril, gremio de recreo y área verde con función ecológica y de ocio.

Founded in 1984, Ataforma has become a referential for the market. Its product is exported to over 50 countries, leading its segment in Brazil. The company is located in an urban area of 30,000 m², comprising a manufacturing complex, a recreational center, as well as a green area with ecological and leisure function.



Travessa Carlos Gardel, 82 | Chácara Califórnia | CEP 16026 630 | Araçatuba - SP - Brasil
55 18 3631 1777 | 3631 5027 | ataforma@ataforma.com.br | www.ataforma.com.br



55 18 98207 0393



facebook.com/ataforma

